

# HKS700E

## Installation Instructions Manual

**Please read this manual before engine installation.**

Keep this manual after installation.

Engine S/N: \_\_\_\_\_



2002 December  
Ver. 2.01

HKS CO., LTD  
7181 KITAYAMA FUJINOMIYA  
SHIZUOKA  
418-0192 JAPAN  
TEL 0544-54-1781  
FAX 0544-54-1410  
hks\_aviation@hks-power.co.jp  
[http://www.hks-power.co.jp/hks\\_aviation/](http://www.hks-power.co.jp/hks_aviation/)

---

# HKS 700E

---

CONTENTS	PG-1/2
1. INTRODUCTION	PG-4
2. GENERAL INFORMATION	PG-4
3. MOUNTING THE ENGINE	PG-5
3.1 Attaching the Engine to the Engine Mount	
4. EXHAUST SYSTEM	PG-7
4.1 Preparing the Exhaust Manifold	
4.2 Installing the Exhaust Manifold	
4.3 Installing the Muffler	
5. LUBRICATION SYSTEM	PG-9
5.1 Installing the Oil Tank	
5.2 Installing the Oil Cooler	
5.3 Installing the Oil Lines	
6. FUEL SYSTEM	PG-12
6.1 Installing the Fuel Pump	
6.2 Installing the Fuel Lines	
7. ELECTRICAL EQUIPMENT	PG-15
7.1 Ignition Coil Installation	
7.2 CDI Units & Regulator Installation	
7.3 Battery	
7.4 Starter Relay	
7.5 Fuse	
7.6 Wiring	
7.6.1 Ignition Cable	
7.6.2 CDI Unit	
7.6.3 Regulator	
7.6.4 Starter Motor	
8. ENGINE INSTRUMENTS	PG-19

---

# HKS 700E

---

9. PROPELLER	PG-21
9.1 Rotation	
9.2 Prop hub dimensions	
10. ENGINE CONTROL CABLES	PG-22
11. STARTING THE ENGINE THE FIRST TIME	PG-23

## HKS 700E

---

 **WARNING!**

This is a non-certified aircraft engine; the possibility of engine failure exists at all times. Do not operate this engine over densely populated areas. Do not operate this engine over terrain where a safe, power off landing cannot be performed.

The operating and maintenance instructions supplied with this engine must be followed at all times. Flying any aircraft involves the risk of injury or death, building and maintaining your own aircraft requires great personal responsibility.

# **HKS 700E**

---

## **1. INTRODUCTION**

The HKS 700E engine has been specifically developed for use in Ultra light type and homebuilt aircraft. All flights must be made according to the aviation and airworthiness regulations of your specific country. The HKS 700E is not intended for use in certified aircraft,(airplanes or motor gliders). This information is intended to assist in achieving the correct installation and operating conditions for the engine. Please use the optional parts sold from HKS for your installation. Information in this document and the part numbers in the figures correspond to the parts contained in optional parts list. Please fill in the ordering sheet attached to obtain the optional parts. The engines must be run with accessories supplied, approved, or recommended by HKS. Modifications must not be made without the approval of HKS.

Please follow the installation instructions carefully.

## **2. GENERAL INFORMATION**

In addition to this installation instruction manual, please refer to the following.

- (1) HKS 700E Operations Manual
- (2) HKS 700E Parts List
- (3) HKS 700E Service Manual

## HKS 700E

---

### 3. MOUNTING THE ENGINE

The HKS 700E must be mounted horizontal to the aircraft (propeller shaft and cylinder heads horizontal). The engine will not run in an inverted (engine upside down) or vertical installation.

#### 3.1 Attaching the engine to the engine mount

- Refer to Fig.1 for the engine mount dimensions.
- The four engine mount bosses on the bottom of the crankcase must be used to attach the engine to the engine mount. These bosses are 10mm x1.25mm pitch. The engine mount is attached with the bolts or studs, lock washers and self lock nuts.
- The engine must be isolated from the airframe using rubber type isolators between the engine/engine mount and the airframe.
- The tightening torque for the four 10mm bolts or studs is 4.8kgm. (34ft.lbs)



#### **CAUTION!**

- The engine must be mounted using the mounting bosses.
- Rubber isolator mounts must be used.
- The four 10mm engine mount bolts must be tightened to the specified torque.

# HKS 700E

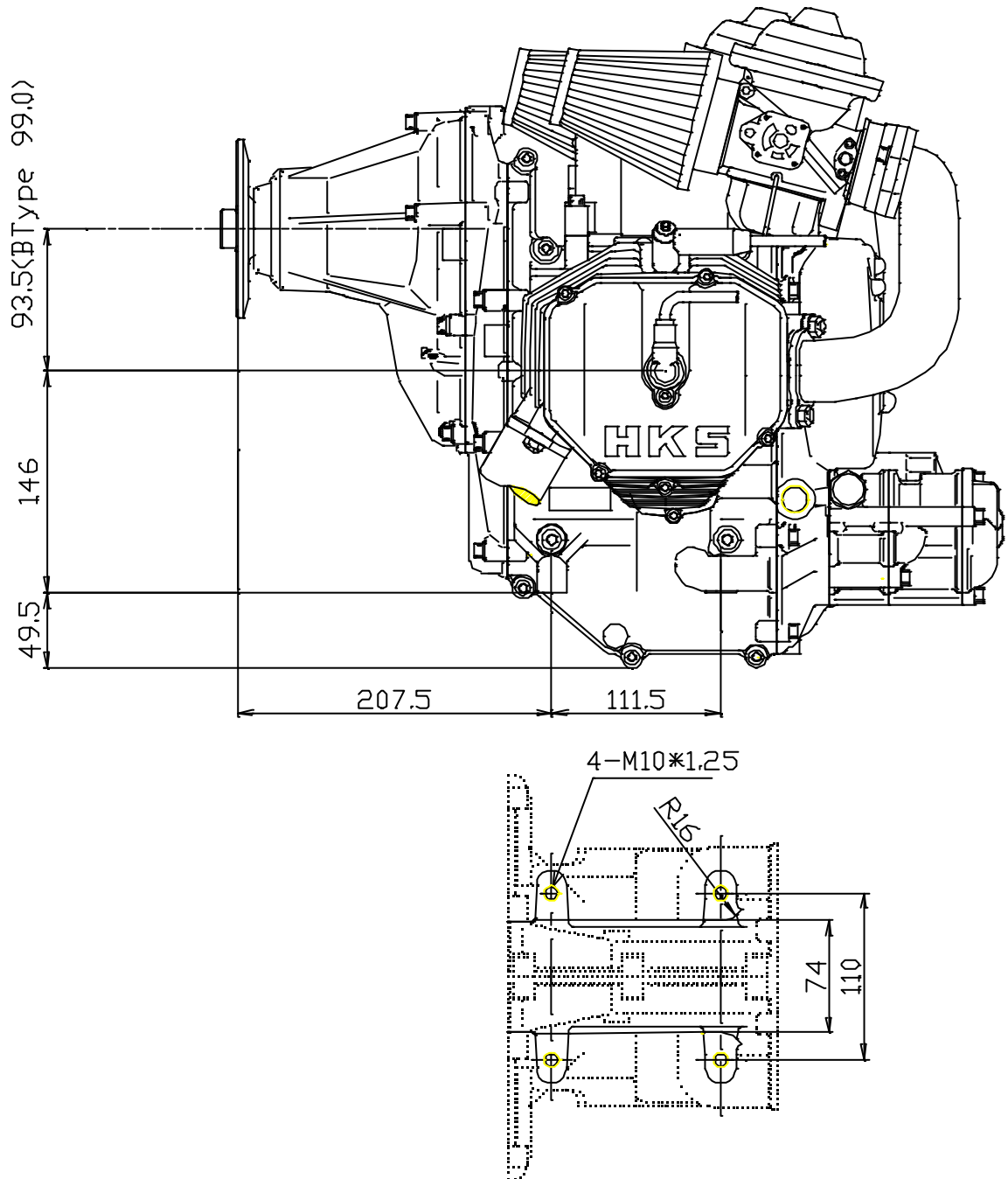

**Fig.1** Engine mount Dimensions

---

## HKS 700E

---

### 4. EXHAUST SYSTEM

Before tightening each individual part, please fit the entire system first exhaust manifolds, junctions and muffler.

#### 4.1 Preparing the exhaust manifolds

Proceed to 4.2 if using an HKS supplied exhaust manifold.

- To create a custom exhaust manifold, refer to the engine and muffler layout in FIG. 3 for a basic reference.
- On the engine side, weld the flange to the manifold pipe.
- Weld the spring hooks at the junction of the manifold and the muffler. The dimension for L in Fig.3 should be 70mm (2.7in.).

#### 4.2 Installing the exhaust manifold

- Place the exhaust gasket between the exhaust flange and the exhaust port of the engine (refer to Fig.3).
- Tighten the nuts evenly so that the flange will seat flat.

#### 4.3 Installing the muffler

- Extend the exhaust outlet with additional stainless tubing if needed.
- Insert the manifold pipe into the muffler and attach with the springs provided.
- Use rubber isolators in the design of the muffler mount between the exhaust system and the airframe.

 <b>CAUTION!</b>
---

- |  |
|--|
| <ul style="list-style-type: none"><li>• Rubber isolators must be used to mount the muffler, otherwise damage to the exhaust system will occur.</li></ul> |
|--|



# HKS 700E

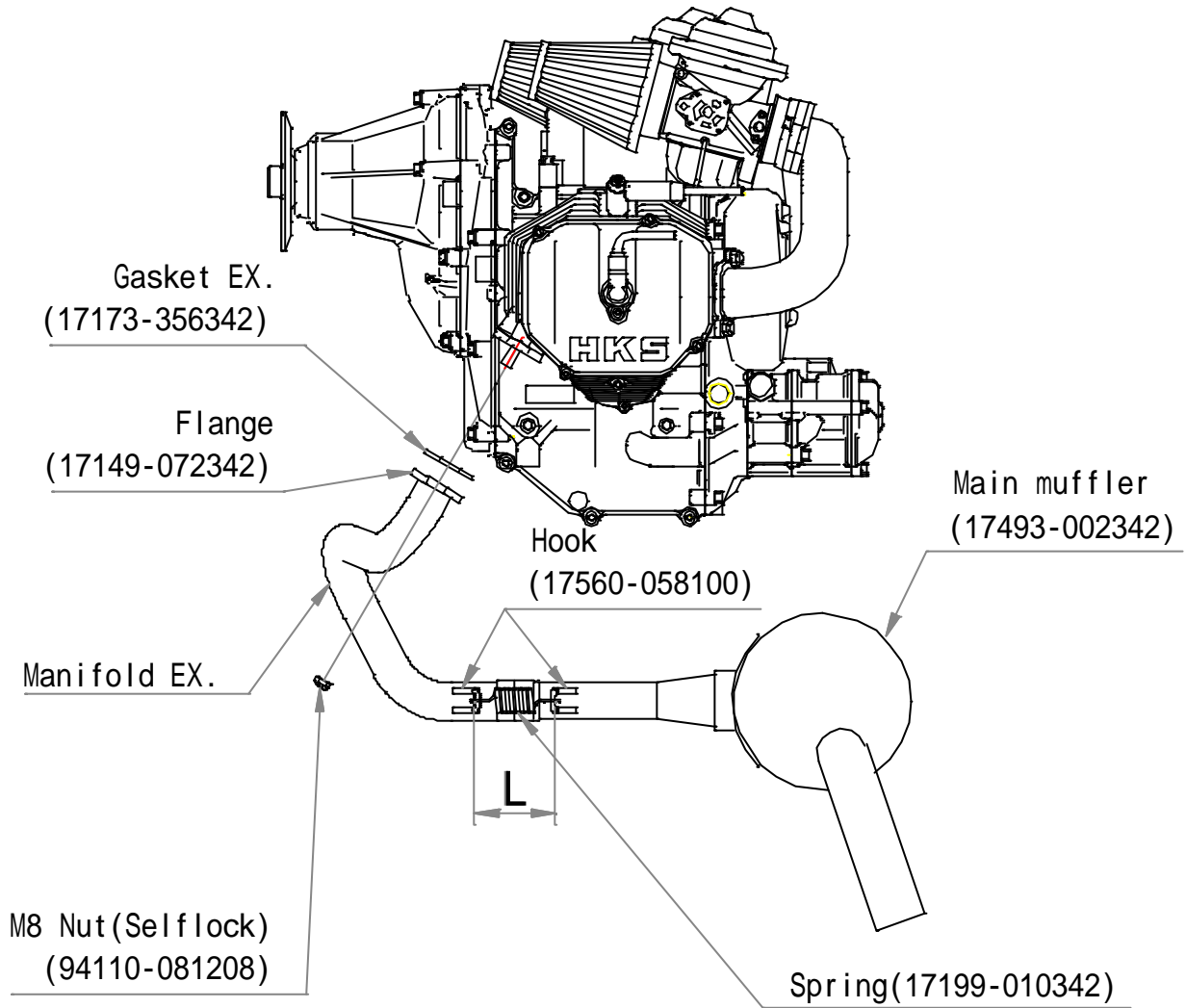

**Fig.3 Exhaust System**

---

# HKS 700E

---

## 5. LUBRICATION SYSTEM

### 5.1 Installing the dry sump oil tank

Please pay attention to the following for the oil tank installation (Refer to Fig.4).

- The oil tank cap must be between 50mm. (2in.) above and 200mm. (7-3/4in.) below from the oil outlet of the engine when the tank is mounted.
- To avoid heat, keep the tank away from the exhaust system.
- Mount the tank in a position to keep the hose between the oil tank outlet and engine inlet ('A' in Fig 4.) as short as possible.

### 5.2 Installing the oil cooler

Please pay attention to the following for the oil cooler installation (Refer to Fig.4).

- Mount the cooler in a position lower than the oil tank.
- Mount the cooler in a position that receives unrestricted airflow.
- Mount the oil cooler so that the cooler core is at a right angle (90 Deg.) to the local airflow.
- The oil inlet and outlet should be upwards.



#### **CAUTION!**

- The oil cooler must be mounted below the dry sump oil tank. If the cooler is located higher there is the possibility of oil overflowing from the tank after shutting down the engine.

---

## HKS 700E

---

### 5.3 Installing the oil lines

Follow Fig.4 for oil line connections.

- Cut the hose to appropriate length so that there are no tight bends (where the hose might kink and restrict the flow of oil). Use elbow fittings when changing hose direction.
- Follow the hose manufacturer's instructions when attaching the fittings to the hose ends.
- Avoid the hose from touching the engine case. Clamp and protect the oil lines to avoid chafing and allowing vibration to weaken the hoses and connections.
- Tighten the fittings securely.
- Oil tank vent line ('B' in Fig.4) must first go upwards 100mm. (4in.) or more from the oil tank union and then downwards and led out of the plane.

Hose length and fittings will vary with engine and auxiliary equipment layout. Please order hose and fittings with the order sheet attached to this manual. See the included Aeroquip Catalogue for fitting types and hose assembly instructions.

Recommended oil hose : Aeroquip AQP Racing Hose FBA1000

Recommended hose fittings : Aeroquip S.A.E. 37deg. swivel

 <b>CAUTION!</b>
---

- |   |
|---|
| <ul style="list-style-type: none"><li>• Please use the specified hose and fittings for oil lines.<br/>Oil line damage resulting in oil loss can cause engine damage or failure.</li></ul> |
|---|

# HKS 700E

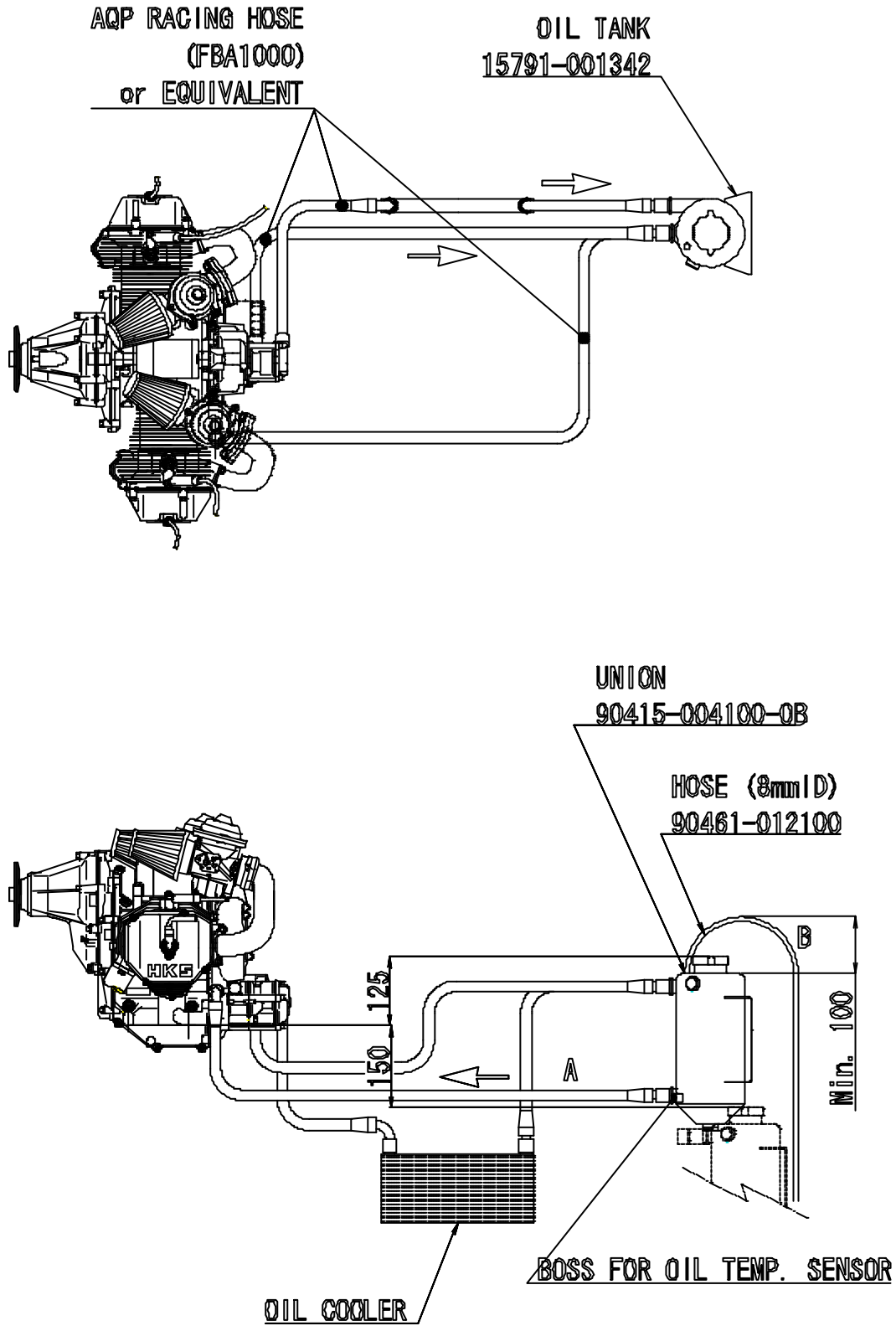

Hose fittings must be attached to both ends of the AQP Racing Hose.

**Fig.4** Lubrication System Diagram

---

## HKS 700E

---

### 6. FUEL SYSTEM

Fuel is supplied to the two carburetors by the fuel pump. The intake pulse pressure from the right intake pipe nipple actuates this pump pneumatically. 'A' in Fig.5 shows the actuating (pulse) line for this purpose.

#### 6.1 Installing the Fuel Pump

Please pay attention to the following for the fuel pump installation (Refer to Fig.5).

- The fuel pump must be located below the fuel tank level.
- Mount the pump securely with two 6mm. bolts.
- To avoid vapor lock, install the pump in a cool, well-ventilated place. Do not mount the fuel pump on the engine itself.
- Mount the pump so that the actuating line nipple is downwards as in figure 5.
- Mount the pump in a position where the fuel pump and actuating line would be higher than the intake pipe nipple.
- The pump actuating line should be no longer than 500mm (20in.) with no slack.
- The pressure in the fuel line between pump and carburetor must be minimum 2.2 psi (0.15 bar) and maximum 5.8 psi (0.4 bar) to ensure sufficient fuel supply. (See Operations manual Sec 3.5)
- If the tank is lower than the engine, an electric pump must be used instead of the pneumatic fuel pump. If the electric pump supplies too much pressure, using a pressure regulator is the proper solution.

 <b>WARNING!</b>
---

- |  |
|--|
| <ul style="list-style-type: none"><li>• Please carefully follow the instructions in 6.1 for the fuel pump installation. An improper installation causing improper pump operation will lead to engine stoppage.</li><li>• If the tank is lower than the engine, <b><u>an electric pump</u></b> must be used instead of the pneumatic fuel pump.</li></ul> |
|--|

---

## HKS 700E

---

### 6.2 Installing the Fuel Lines

Follow Fig.5 for proper fuel line connections.

- In a gravity feed fuel system install a fuel shut-off valve where it can be operated from the cockpit.
- Adjust the fuel lines to appropriate length so that there are no tight bends (where the fuel lines might kink and cut off fuel flow).
- Avoid the fuel lines from touching the engine, clamp and protect the fuel lines to avoid chafing and allowing vibration to weaken the hoses and connections.
- Fit a fuel filter between the fuel shut-off valve and the fuel pump (See Fig.5).
- All fuel line connections must be secured with hose clamps or other approved methods.

 <b>CAUTION!</b>
---

- |  |
|--|
| <ul style="list-style-type: none"><li>• In a gravity feed fuel system, a fuel shut-off valve must be installed. It is needed to stop fuel in case of emergency. It is also needed to prevent fuel overflow from the carburetor when engine is not running.</li></ul> |
|--|

# HKS 700E

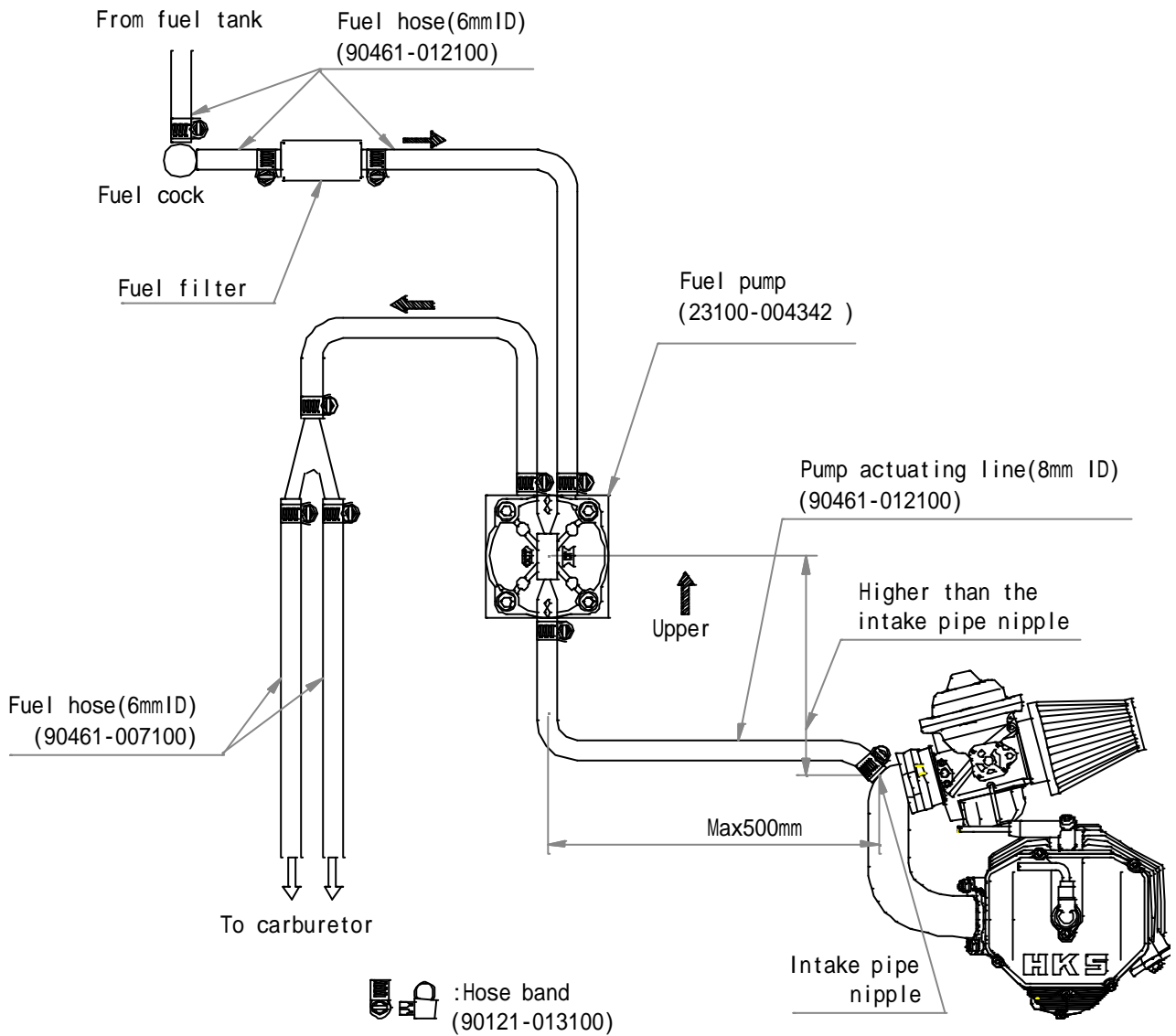

**Fig.5** Fuel System Diagram

---

# HKS 700E

---

## 7. ELECTRICAL EQUIPMENT

Please refer to the electric equipment diagram in Fig 6.

### 7.1 Ignition Coil Installation

Please pay attention to the following for the ignition coil installation.

- Two ignition coils are used. The coils come with factory installed connectors.
- Mount the coils where the ignition cables can reach the spark plugs, but in a position where they will be properly cooled with airflow during engine operation. The maximum ambient temperature is 140 Deg. F (60 Deg. C).
- Ground the ignition coil mounting bolts.



#### **WARNING!**

- Do not mount the ignition coils on the engine itself. The coils must be properly cooled during engine operation.

### 7.2 CDI Units & Regulator Installation

Please pay attention to the following for the CDI Units & regulator installation.

- Mount the CDI Units and regulator where the maximum ambient temperature is 140 Deg. F (60 Deg. C).



#### **WARNING!**

- The maximum ambient temperature of the ignition system is 140 Deg. F (60 Deg. C).

### 7.3 Battery

The battery is an important component in the HKS 700E ignition system.

- The battery must be 12 volt.
- Battery must have at least 10Ah capacity. A 12 Ah is preferable.

Use a sealed lead acid type battery, and they are commonly used on recreational motor craft, such as "Quad type" All terrain vehicles (ATVs).



## **HKS 700E**

---

### **7.4 Starter Relay**

A starter relay must be used to run the starter motor (refer to Fig.6).

### **7.5 Fuse**

Fuses must be installed in the following places.

- Between the charging circuit (regulator) and main power supply, 20Amp.
- Between the CDI units and main power supply (one for each unit), 3Amp.
- Between the electrical accessory terminal (shown as user load terminal in Fig.6) and the main power supply.

The fuse requirement will vary with the accessories load.

### **7.6 Wiring**

Please follow the wiring diagram in Fig.6. If an extension lead is required, please order terminal connectors.

#### **7.6.1 Ignition Cables**

The lengths of the two cables from the ignition coils are different. The connector on the longer cable is for the spark plug located in the center of the cylinder only. Refer to Fig.6 for connections. To avoid shorting the cable or breakage, keep the cables away from touching cylinders or cylinder heads. Protect with spiral cut polyethylene tubing, a fuel line/tie-wrap standoff or clamp if necessary.

#### **7.6.2 CDI Units**

The CDI units come with pre-attached connectors.

- **CDI units to the Ignition coils**

Connect the orange wires together. If an extension lead is required, use a single (1) pin type connector.

- **CDI units to the ignition pick-up**

Connect the wires from the CDI units to the ignition pick-up using the chart below for reference and if an extension lead is required, Use a two (2)-pin connector.

#1 CDI to Pick-up A  
RED ----- RED  
WHITE --- WHITE

#2 CDI to Pick-up B  
RED ----- GREEN  
WHITE --- BLACK

---

## HKS 700E

---

- **CDI units to the Power supply**

If an extension lead is required, Use a two (2)-pin connector.

Insert a 3 amp. fuse and the ignition switch to the brown wire from the CDI unit and connect to the positive side of the power supply. Connect the black wire to ground.

### 7.6.3 Regulator

Use the 3-pin and 5-pin connectors to prepare a connection cable.

- **Regulator to the Alternator**

Connect the three white wires each together.

- **Regulator to the Power supply**

Insert a 20 amp. fuse to the red wire from the regulator and connect to the positive side of the power supply. Connect the black wire to ground.

### 7.6.4 Starter Motor

Install a starter relay and connect as in the wiring diagram.



#### **WARNING!**

- Use a minimum of 10mm<sup>2</sup> (6 gauge) or heavier, flexible, multi strand cable for the following:
  - (1) The starter motor to power supply cable
  - (2) The engine ground cable\*
  - (3) The battery ground cable

\*Note: Do **not forget** the engine ground cable (2). This cable must be connected to the bolt that attaches the starter motor to the engine.

The CDI unit will be destroyed while turning on the starter motor if without this cable.

# HKS 700E

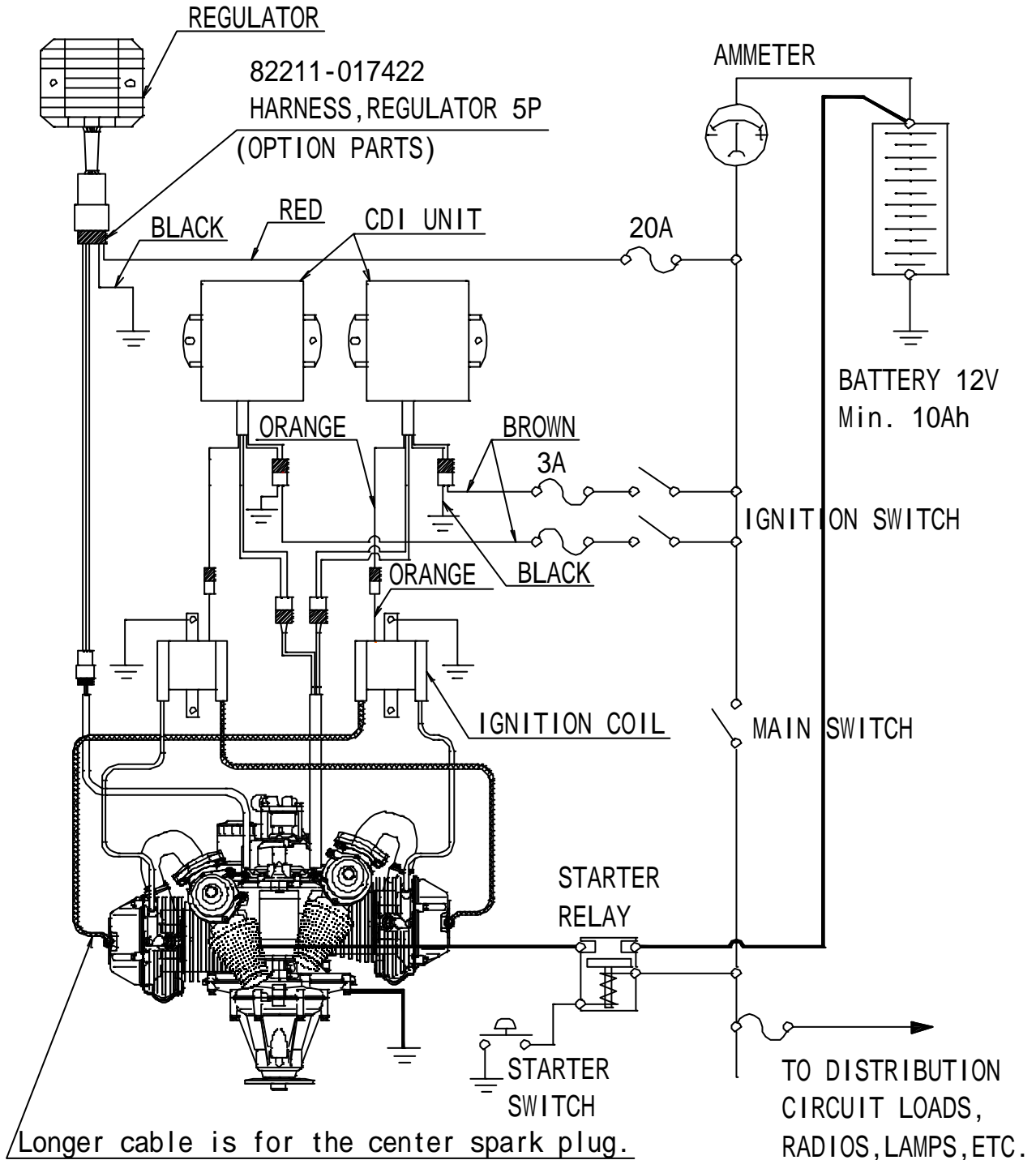

**Fig.6** Electrical Equipment Wiring Diagram

---

# HKS 700E

---

## 8. ENGINE INSTRUMENTS

In order to run the engine properly, the following instruments are required to monitor the HKS 700E operating conditions.

### (1) Engine tachometer

Following two lines are usable for sensing the revolution.

- \* The trigger line between the CDI unit and the ignition coil. (1 pulse/rev)  
Install the genuine tachometer (83380-005100) at this line.

- \* The AC line of the generator. (6 pulses/rev)

### (2) CHT (Cylinder Head Temperature gauge)

Install the bayonet style CHT probe units (sensors) in the threaded bosses that are prepared on cylinder heads. See Fig.7.

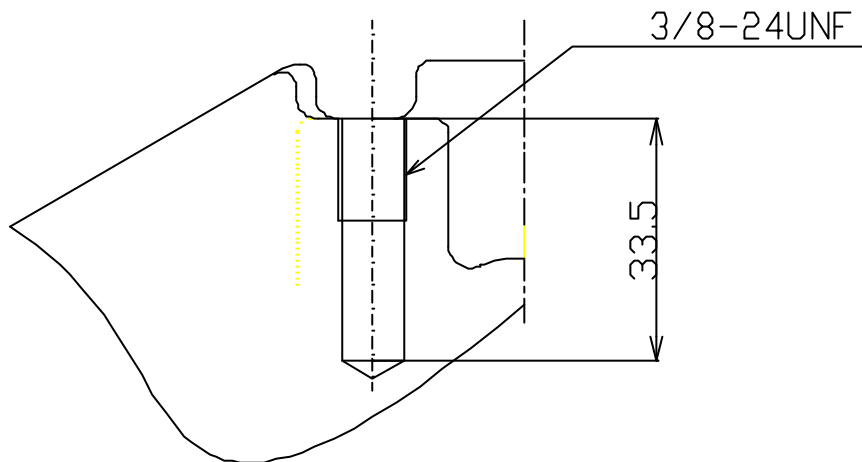

**Fig.7** Bayonet sensor Boss Dimensions

### (3) Oil temperature gauge

Install the oil temperature sender (sensor) in the threaded boss at the bottom of the oil tank the thread 1/8" PT. See Fig.4.

### (4) Oil pressure gauge

Install the oil pressure sensor to the plugged hole near the oil filter mount on the rear cover, the thread is 3/8" PT. Remove the tapered plug (90311-018342) which has been inserted before shipping. Use the 3/8"PT to 1/8" NPT adapter (90311-023342) supplied if needed for the type of sender you choose.

---

## HKS 700E

---

### (5) Ammeter or Voltmeter

An ammeter or voltmeter is required to monitor if the battery charging circuit is operating properly and the charge condition of the battery. An additional use of this instrument is to detect a possible malfunction of the alternator, regulator or if the current drain of accessories are more than the charging circuit can supply.



#### **WARNING!**

- If the battery charging circuit is not operating properly (such as regulator failure, etc.), the engine will be running with electricity from the battery only. If the engine continues to run in this condition, the engine will eventually stop from the ignition completely discharging the battery. Land as soon as is safely possible!

### (6) EGT (Exhaust Gas Temperature gauge)

Install the exhaust gas temperature sending units (sensors) at 20mm apart from the exhaust port flange. In order to get accurate EGT, install this sensor at the lee side of the exhaust pipe to avoid the direct airflow.

# HKS 700E

## 9. PROPELLER

### 9.1 Rotation

The propeller shaft rotates clockwise looking at the propeller-mounting flange from the front (see Fig.8).

Please take this into account when choosing a propeller for the specific engine installation configuration (tractor, pusher).

### 9.2 Prop flange dimensions

There are three ways to install the propeller to this engine.

- (1) Use 8mm.x1.25 bolts to mount using the threaded bores on the flange. (P.C.D 75mm)
- (2) Mount with AN4 bolts and nuts. (P.C.D. 75mm)
- (3) Mount with AN5 bolts or 8mm bolts with nuts. (P.C.D. 100mm) "B" Gear Box is provided with this 100mm P.C.D. holes.

Dimensions for the propeller-mounting flange are shown in Fig.8.

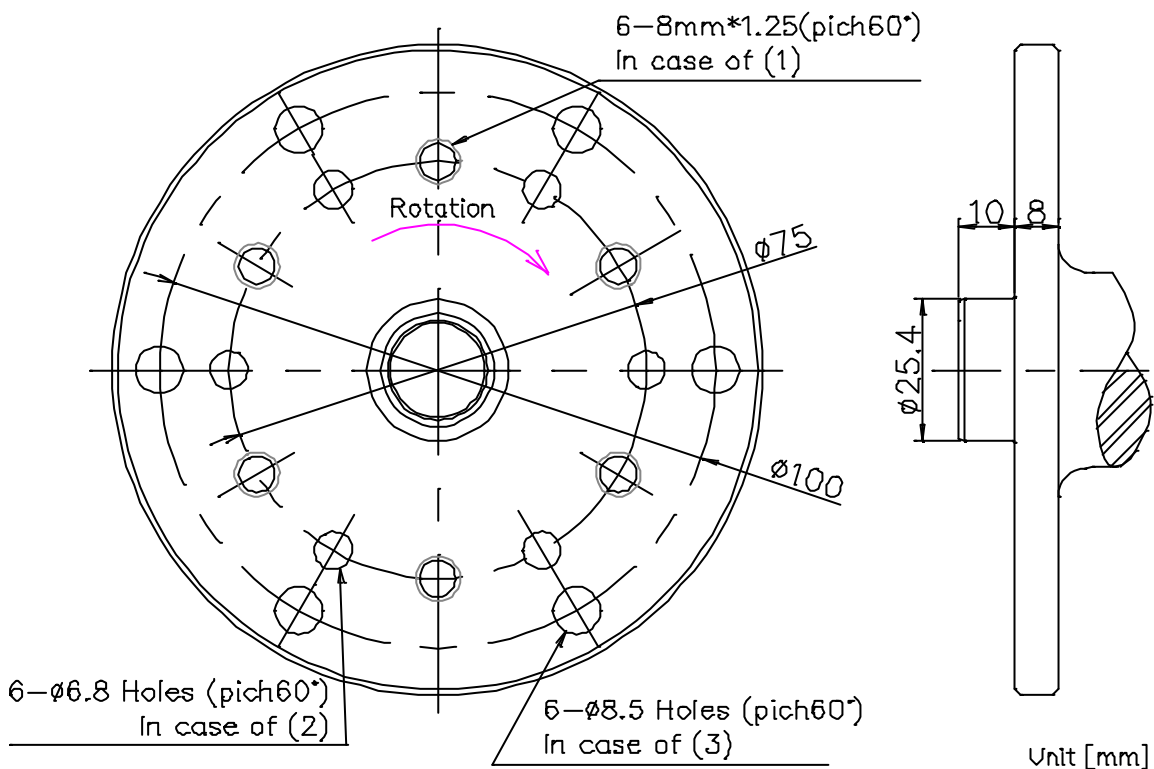

**Fig.8** Propeller Mounting Flange Dimensions

## **HKS 700E**

---

### **10. CONTROL CABLES**

Use wire cables for throttle and choke operation. A throttle and the choke wire cables are available as an option parts. Please see the parts list.

## HKS 700E

---

### 11. STARTING ENGINE THE FIRST TIME

- Recheck the wiring according the electrical schematic in Fig.6.
- Fill the oil tank with the recommended oil (See the operators manual for type), The minimum amount is 3 liters of oil. This will vary with the specific installation.
- Check the range and free movement of the throttle lever. (NOTE 19) When starting the engine the first time, with the ignition OFF, crank the engine with the starter for supplying oil into the engine. If using the minimum size battery connecting a bigger capacity battery may be required.

Engine instruments must be installed to monitor the engine operating conditions. (Refer to Sec.9.)

- Ignition and Main switch OFF.
- Remove all four spark plug caps and remove the upper plugs (plugs marked in Fig.6) on the left and right cylinders.
- Main switch ON.
- Engage the starter and confirm if oil pressure registers on the oil pressure gauge. If not, check the oil lines and the oil pressure sensing system.
- Main switch OFF.
- Reinstall the spark plugs and attach the plug caps.
- Make certain that there is adequate fuel in the fuel tank and that the fuel pump is operating properly. (Refer to Chapter 6.1)
- Please refer to the more specific operating instructions found in Chapter 5.1 in operations manual.



---

# HKS 700E

---

Log of revisions.

Revision No.	Date	Pages affected	Description	Signature
1	Dec. 25,1997	3a, 12	Warning for fuel pump and add this page.	
2.00	Dec. 20,1999			