

HKS 700E

**60hp Four-Stroke
Sport Engine**



HKS

Power's Here!

Pursuing the Ultimate in Engine Performance and Efficiency.

Description

*Air-cooled, four-stroke. 2 cylinders, horizontally opposed.
Dry sump forced lubrication. Oil cooled cylinder heads.
Nickel ceramic composite coated cylinders.
One central camshaft-pushrods-OHV, hydraulic lifters.
Dual CDI, Electric starter, Generator*

HKS AVIATION
HKS AVIATION CO., LTD.

MADE IN JAPAN

HKS 700E 60hp Four-Stroke Sport Engine

Specifications :

- Configuration :** 2 Cylinders 4-Stroke Engine
with Horizontally Opposed Cylinders
4 Valves per Cylinder
- Bore × Stroke :** 85 mm × 60 mm
- Displacement :** 680 c.c.
- Compression Ratio :** 11.3:1
- Power Output :** 56hp(41kw) at 5800rpm (continuous)
60hp(44kw) at 6200rpm (3min./Take off)
- Torque Max. :** 7 kgm at 5000rpm
- Max RPM :** 6200 RPM
- Cylinders :** Nickel Ceramic Composite Coated
Cylinders
- Pistons :** PVD Coated Piston Rings
- Valve Gap :** Automatic Adjustment by Hydraulic
Lifters
- Camshaft :** One Central Camshaft-Pushrods-OHV
- Direction Of Rotation :** Counter Clockwise
(Looking from pilot seat, tractor configuration)
- Cooling :** Air-Cooled Cylinders
Oil-Cooled Cylinder Heads
- Lubrication :** Dry Sump Forced Lubrication by Trochoid Pump,
Camshaft Driven (Pressure pump & scavenge pumps equipped)
- Ignition System :** Dual CDI (Capacitive Discharge Ignition)
- Generator Output :** AC-12Volts 210Watts
- Regulator/Rectifier :** Three Phase Regulator
- Starter :** Electric Only
- Spark plugs :** HKS S40i (NGK Heat range #8)
- Electrode spacing :** 0.8 mm (.031")
- Fuel Consumption :** Approx. 9 Liters/hour at 4750rpm
- Reduction Gear :** Integrated With Torsional Shock Absorption
- TBO :** 300 hours (Expect higher TBO with fleet experience)
- Standard Version includes :** Carburetors with clamps, Fuel Pump
Air Filter, Gear Box, Electrical Equipment

Weights :

Engine:	49.1 kg	108 lbs.
(Dry, With all Electrical Equipment, Electric Starter, Carburetors and Gearbox)		
Exhaust System:	3.2 kg	7 lbs.
Oil Tank & Cooler:	2.7 kg	6 lbs.
Totals:	55.0 kg	121 lbs.

Optional features :

- Reduction Box :** "A" box with ratio: 2.58
"B" box with ratio: 3.47

Side View(Gearbox up)

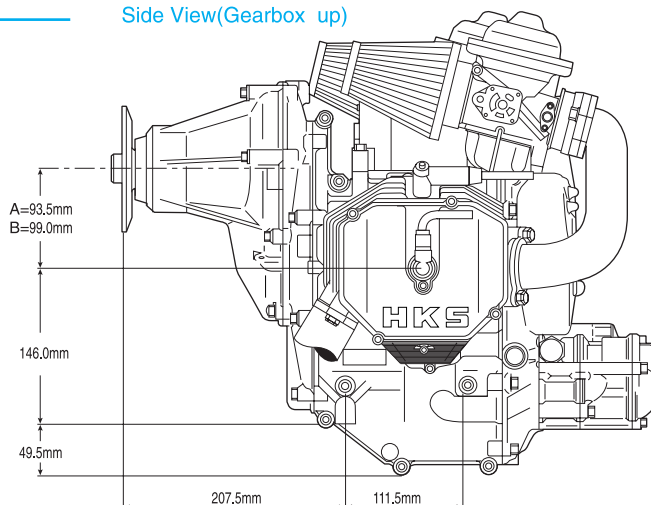

Side View(Gearbox down)

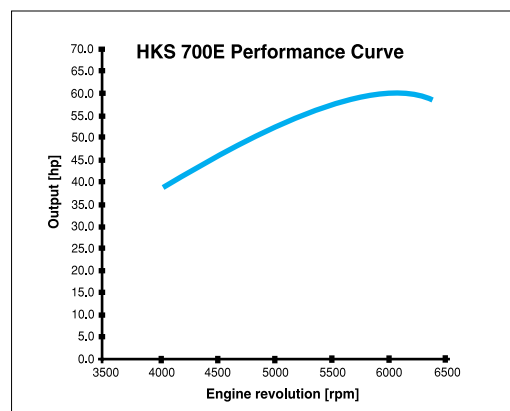
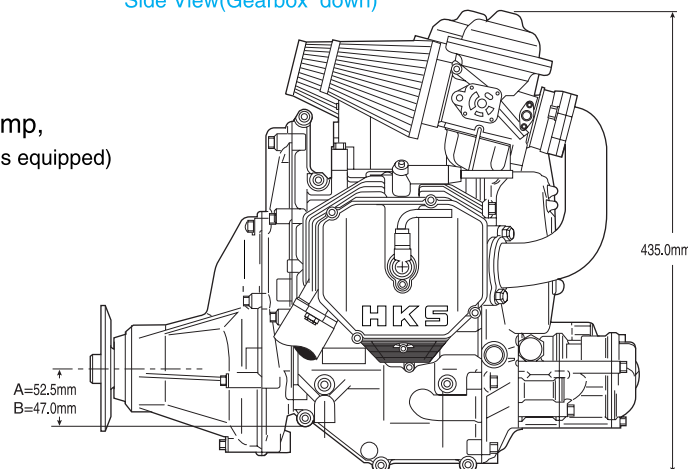

7181 Kitayama, Fujinomiya-shi, Shizuoka-ken 418-0192 JAPAN
Tel. +81- (0) 544-54-1781 • Fax +81- (0) 544-54-1410
E-mail : hks_aviation@hks-power.co.jp
HomePage http://www.hks-power.co.jp/hks_aviation/

WARNING! This is a non-certified aircraft engine, the possibility of engine failure exists at all times. Do not operate this engine over densely populated areas. Do not operate this engine over terrain where a safe, power off landing cannot be performed. The operating and maintenance instructions supplied with this engine must be followed at all times. Flying any aircraft involves the risk of injury or death, building and maintaining your own aircraft requires great personal responsibility.

MADE IN JAPAN

HKS AVIATION AUTHORISED DISTRIBUTOR