

STABILIZER DIHEDRAL AS SHOWN

9/16

MODIFY BELLCRANK AS SHOWN

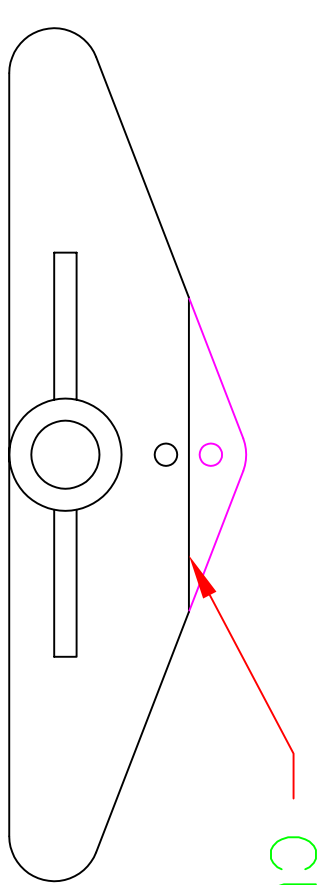

CUT OFF HERE

LEADOUTS (0.018" PIANO WIRE)

BELLCRANK MOUNT (1/16" PLY)  
BOTH SIDES OF WING

WING SKID (CARL GOLDBERG #461) BOTH WINGS

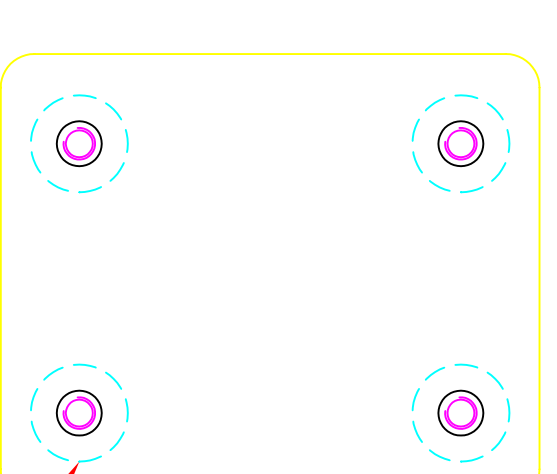

4 #2-56 BLIND NUTS (DU-BRO #133)  
(MOUNTED ON SIDE OPPOSITE ENGINE)

MOTOR MOUNT  
1/8" PLY

MOTOR MOUNT

COWL (BALSA BLOCK)

WING (3/16" BASS)  
THIN TO 1/8" AT TIPS

FUSELAGE (1/4" BASS)

PUSH-ROD (0.055" PIANO WIRE)

SKID DRILLED AS SHOWN  
FOR LEAD-OUT WIRES

LANDING GEAR (3/32" PIANO WIRE)

WHEEL (PERFECT #PEF65)

TAIL SKID (0.055 PIANO WIRE)

STAB & ELEVATOR  
(3/32" or 1/8" BASS)

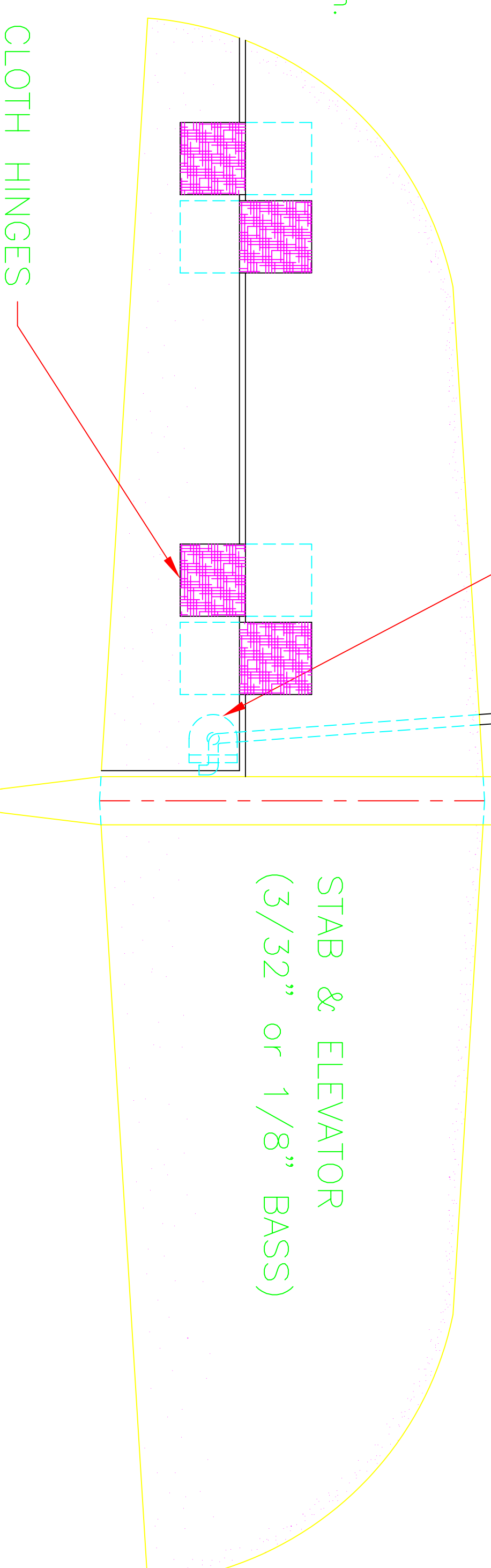

CLOTH HINGES

CONSTRUCTION NOTES:

- 1) Cut out all pieces to the plan outlines. Thin wing as noted then shape airfoil with a flat bottom. Drill holes for bellcrank screw and wing skids.
- 2) Shape stabilizer and cut in half at centre (root). Form the dihedral as shown and glue with medium instant glue. When cured, cut out elevator as shown. Drill elevator to accept horn and fasten elevator to stabilizer with cloth hinges.
- 3) Cut openings in fuselage to accept wing and stabilizer in the locations on the plan. Glue wing in place using slow set epoxy ensuring it is square with fuselage. When the glue has cured, mount the stabilizer to the fuselage using slow set epoxy and allow to cure.
- 4) Mount balsa cowl (made up of 4 separate pieces) to wing and fuselage joint using slow set epoxy and allow to cure. Sand front of fuselage and cowl flat and square and cut a groove in the fuselage to accept the piano wire landing gear. Drill a shallow hole in the top of the fuselage for the hook portion of the landing gear to fit into. Trial fit the motor mount to the front of the fuselage with the landing gear in place – it should fit tightly against the fuselage and cowl with no large gaps. You will have to remove some balsa from the cowl to clear the motor mount blind nuts.
- 5) Using slow set epoxy, glue the landing gear and motor mount in place and use a clamp or elastic bands to hold it while the glue cures. Add reinforcing nylon or fibre glass tape around the periphery of this joint for extra strength using slow set epoxy.
- 6) Mount wing skids, tail skid, and bellcrank mounts using slow set epoxy.
- 7) Sand entire model and cover with two coats of slow set epoxy or finishing resin. Paint with colour as desired.
- 8) Mount bellcrank, and bend push rod to suit. Mount horn to elevator. Controls should be neutral with bellcrank in position shown. Mount wheel using a washer and Sloy-Brite solder and install leadouts in the bellcrank. Check balance and adjust if needed.  
HAPPY FLYING!

1/2A BELLCRANK & HORN (SIG SH-234)

# MACLEAN RACING

TORONTO, CANADA

## STREAKER IV MOUSE RACER

A 1/2 A Class racing/sport control-line model for tank mount reed valve engines. A pure-bred champion with a pedigree!

ORIGINAL SCALE	DESIGNED	DATE
FULL SIZE	R. TURENNE	
INCH DIMENSIONS	DRAWN	DATE
	L. MACLEAN	12/95

SIZE	DWG. NO.	1007	SHEET... 1	ISSUE	1
A2			OF... 1		